

FOLDING WHEELCHAIR INFORMATION SHEET

Your Name: _____

Vehicle year and model: _____ or do this >

Chair Manufacturer: _____

Chair Model: _____

Chair Special features _____

Chair Type: Folding

Dimensions: **A:**

(per diagram below) **B:**

C:

D:

E:

W:

!

Please send rear and side view photos of your chair(s) if you can, taken from axle level.

Key for Folding Dimensions

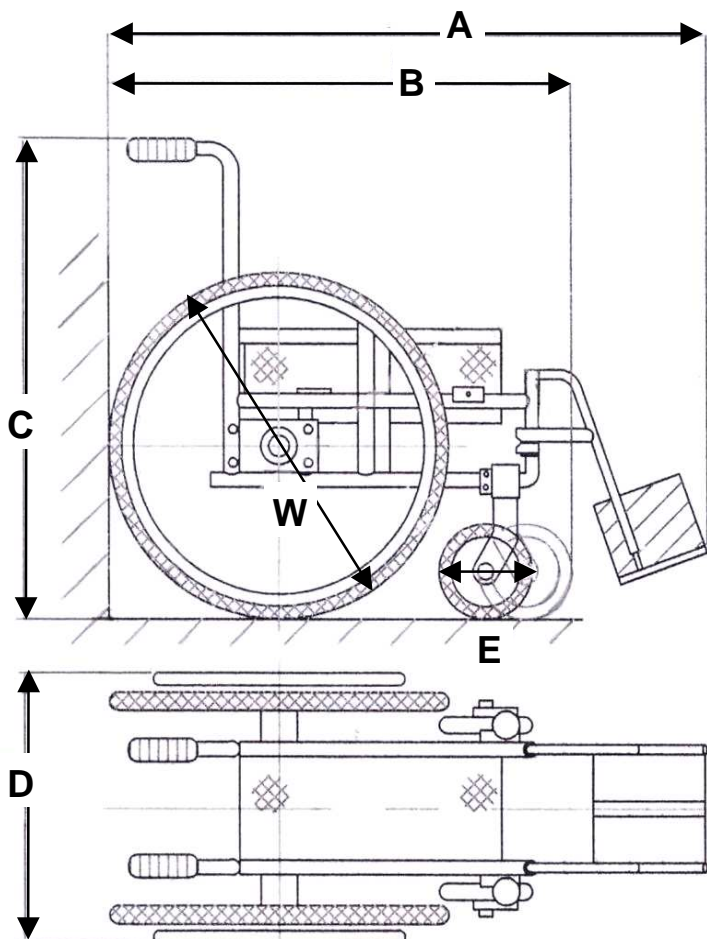

If you need to change your vehicle and want us to recommend one that suits the loader, please guide us in your other requirements or preferences:

Seat squab height best for transfer:

Car \$ range:

Car age range:

Car style: Wagon / SUV / People carrier /

Rear seat will be used: Yes / No /

Cars / Brands I like:

Fuel: Petrol / Diesel / don't care

2 Wheel drive / 4WD / don't care

Transfer in garage Req'd / not important

Other preferences:

Special Notes or Requests: